



RGB-M-505/LN, Low NOx Electronic Modular Gas Burner

Specifications

- Electronic modulating burner with capacity of 700-5100 kW on gas side (70-510 Nm³/h for G20), and turn down ratio of 1:7, and NOx class III.
 - Compatible with all types of combustion chambers according to EN-303 or BS-EN 12953 standards.
 - Suitable for fire tube, firebox, water tube boilers, etc.
 - The burner includes: mechanical components, low NOx burner head designed for emission reduction, flame tube, air fan, control panel, ignition devices, valves and all necessary safety devices in the gaseous fuel line.
 - Burner controller: AUTOFLAME MINI MK8 (in burner/boiler package), and LAMTEC BT or SIEMENS LMV2/3 depends on the policy of the manufacturer based on the market availability or the customer's order.
 - The controller includes: main controller (PID controller), load control module, user interface, and actuators.
 - The gas train includes: filter, regulator, main and safety valve, pressure gauges, maximum pressure switch, minimum and leak test pressure switch (All according to BS-EN 676).
- The recommended gas trains are offered in two types:
- DN65 separate low-pressure gas train (inlet pressure of 228-360 mbar).
 - DN65 separate high-pressure gas train (inlet pressure of 1.5-4 bar).
- Advantages: optimal design, high modulating ratio, silent operation, valve proving system, communication with external systems via Bus, the ability to open from the hinge to both sides, and ease of installation and maintenance.
 - Optional ability: running with FGR (Flue Gas Recirculation) in order to further reduction in NOx level, variable speed drive (VSD), running with O₂ and CO sensors (plus CO₂, NO, NO₂, and SO₂ sensors with AUTOFLAME controller), LPG fuel compatibility with LPG nozzle kits.



More information

- Fan motor: 11 kW, 3 Phase, 380-400 Volt, 50 Hz, 2900 rpm.
- Operating ambient temperature: 5-60°C
- Maximum combustion air temperature: 60°C
- Noise emission level: 84 dB in 1.5-meter distance
- Casing insulation class: IP43
- Net weight: ~221 kg
- Packing dimensions (L x W x H): ~1850 x 1140 x 870 mm

Reference conditions: Ambient temperature 20°C - Gas temperature 15°C
- Barometric pressure 1013 mbar - Altitude 0 m (According to BS-EN 676)

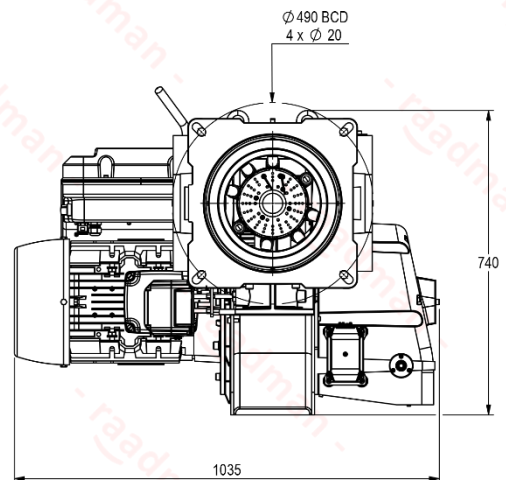
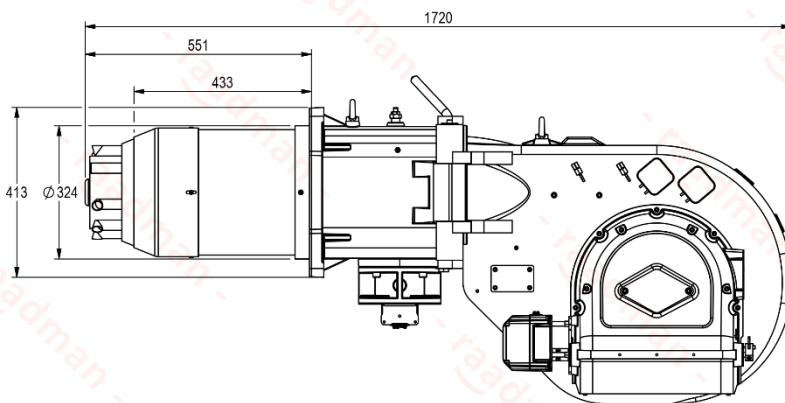
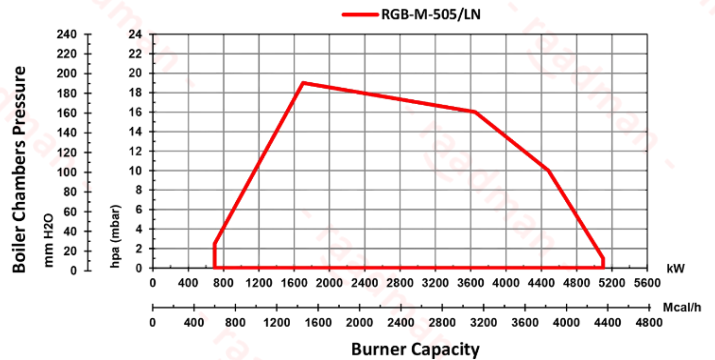

- Suggested boiler flange diameter = 336 mm

Certifications

- Certified in EAEU countries standard No.0378484.
- Certified in Iran national standard ISIRI-7595 (BS-EN 676).



Scan to access:
Technical proposal
Technical data
Technical consultation
Cad model (only for VIP customers)

